

# Technical

TECH01 12/2004

## BUILDER'S GUIDE FOR TERMITE MANAGEMENT

### THIS TECHNICAL CIRCULAR HAS BEEN PREPARED TO ASSIST BUILDERS TO UNDERSTAND THE OPTIONS NOW AVAILABLE FOR COMPLIANCE WITH THE PROVISIONS INCORPORATED INTO THE BCA AND AS3660.1-2000

#### Background

Since 1995, following the banning of the potent organochloride chemicals used in termite management systems, there has been a reported 70% increase in termite infestations. The majority of these have been caused by bridging or breaching of perimeter treatments or negligent installation of the barrier, especially where a chemical system was used.

The current chemicals used today have a limited effective lifespan. The Australian Standard (AS3660.1) introduced in 1995 did not adequately address this durability issue. Furthermore, the Building Code of Australia (BCA) only required the structural elements of a building to be managed against termite attack and not other timber elements such as architraves, skirtings etc.

A new AS3660.1-2000 and a Queensland amendment to the BCA to finally address these issues took effect on 1 January 2001.

#### New Australian Standard

The AS3660.1-2000 Termite Management Part 1

- New Building Work was introduced on 1 January 2001. The Standard sets out the requirements for the design and construction of subterranean termite management systems for new buildings and ground level extensions or renovations. A range of options is provided so that barriers may be used either singly, or in combination, to provide an integrated termite barrier system.

However, the new Standard still does not adequately address problems identified in Queensland. As a result, a Queensland amendment to the BCA overrides the part of AS3660.1 that relates to chemical barriers. It also places additional requirements in the BCA relating to what must be managed from termite attack and how the owner is to be informed of what management system has been installed.

#### The New BCA Requirements

On 1 January 2001, the BCA was amended to incorporate new provisions in Queensland. The amendments only apply to buildings addressed in Volume 2 of the BCA, that is, Class 1 and Class 10 buildings (houses and associated sheds,

**THIS PUBLICATION IS PRODUCED EXCLUSIVELY FOR MEMBERS OF MASTER BUILDERS  
FOR FURTHER INFORMATION PLEASE CONTACT EVAN WOODRUFFE ON (07) 3404 6427 OR EMAIL TECHNICAL@Q MBA.COM.AU**

Master Builders  
Master Builders House  
417 Wickham Terrace  
Brisbane Queensland 4000  
Telephone (07) 3404 6444  
Facsimile (07) 3832 2361  
ask@qmba.com.au  
www.qmba.com.au



garages etc). They DO NOT APPLY to other types of accommodation buildings or commercial or industrial buildings.

The amendments are not retrospective. Houses and associated sheds, garages etc. will be able to be built using the termite management provisions in force prior to January 2001 if:

- Building Approval was received prior to 1 January 2001; or
- An application for Building Approval was lodged prior to 1 January 2001

### **New Requirements for Chemical Treatments**

- If chemical treatment under a slab is utilised as a primary management system, it must be via an approved reticulation system to allow replenishment when the life expectancy of the chemical has expired. **HAND SPRAY UNDER A SLAB IS NOT AN ACCEPTABLE SOLUTION UNDER THE QUEENSLAND AMENDMENTS.** However, provided an approved system is used (e.g. a physical barrier complying with AS3660.1) as the primary system, a hand sprayed chemical barrier may also be used under the slab as an additional precaution, without the need to obtain special approval from the building certifier.
- If chemicals are used for an external perimeter treatment the following procedures are to be adopted:
  - The area to be treated must be trenched and all building debris removed (e.g. mortar droppings). The trench is to be 150mm wide and extend 50mm below the top of the footing.
  - Treat the trench by handspray.
  - Backfill the trench with a suitable material - e.g. loam, and treat the backfill by hand spray or rod injection or a permanent reticulation system.
  - Place a continuous concrete cap (mowing strip) over the treated area. The concrete cap must be continuous, 300mm wide, 50mm thick and 75mm below the weephole. The mowing strip is required even if a reticulated chemical system is used.

### **New Requirements For Durable Notices**

At least 2 durable advisory notices must be installed in every house. The notice is to contain:

- The method of termite management
- The date of installation of the system
- Where a chemical system is installed, its life expectancy as listed on the NRA label
- The installer's or manufacturer's recommendations for the scope and frequency of future inspections for termite activity or when replenishment is required in the case of a chemical system.

The BCA requires the notices to be installed in a conspicuous location. The amendments do not make it mandatory to place the notices at any specific location, however, as a guide it has been suggested that the meter box and kitchen cupboard are appropriate locations.

### **New Requirements On What Must Be Managed From Termite Attack**

The BCA requires the following Primary Building Elements (PBE's) to be managed from termite attack.

"A member of a building specifically designed to take part of the building loads and includes roof, ceiling, floor, stairway or ramp and wall framing members including bracing materials designed for the specific purpose of acting as a brace to those members".

The Queensland amendment extends this to include "Door jambs, window frames and reveals, architraves and skirtings".

### **Appraisal of the Changes**

#### **Termite Resistant Materials**

The inclusion of architraves, skirtings, door jambs, window frames and reveals to be managed against termite attack DOES NOT mean that they must be of termite resistant materials. If an underslab and perimeter system (either physical or chemical or a combination) is installed in accordance with AS3660.1 and the additional BCA requirements, nothing further has to be done.

Builders who have in the past relied upon using termite resistant materials as the Primary Building Elements (e.g. steel frame or termite resistant timber such as cyprus), without the need to install an underslab or perimeter treatment must now rethink their method of construction. Unless an underslab (including penetrations) and perimeter treatment is installed the architraves, skirting, etc., must be of termite resistant material.

If preservative treated timbers are to be used they must achieve a hazard level of H2 when used in the interior of the building above ground, H3 used in the exterior above ground and H4/H5 when used in the exterior and in contact with the ground.

Wood products such as particleboard, MDF board etc. should not be considered as termite resistant unless the manufacturer of the product can demonstrate that they are termite resistant.

#### **Chemical Treatments**

The requirement to trench when installing a chemical perimeter system ensures that all building debris is removed and provides a greater level of assurance that the perimeter barrier will be installed correctly.

Available evidence suggests that termite infestation is more predominant via the perimeter of the building. This may be as a result of inadequate treatment or by an unsuspecting homeowner or contractor inadvertently breaching or bridging the barrier, e.g. placing a new garden bed or turf over the barrier. The requirement for a concrete “mowing strip” will reduce the likelihood of inadvertent bridging or breaching of the chemical barrier.

The use of a reticulated system under the slab will negate the requirement and additional costs for the homeowner to drill through the slab for retreatment when the life expectancy of the chemical has expired.

The new requirements associated with chemical management systems will add significant costs to the traditional hand spray method. The vast price differential between physical barrier systems and traditional hand spray methods is negated and provides for a level playing field.

#### **Impact On Alterations/Additions/Renovations**

A building certifier must decide if any new building work involving an alteration or addition to an existing building can comply with the previous provisions of the BCA or whether the new work must comply with the new provisions. For example, it may be proposed to add a new slab-on-ground bedroom extension to an existing slab-on-ground house. If the existing house was treated using a hand sprayed chemical system under the slab, the building certifier may allow the same treatment to

be used on the extension provided it can be shown that the structural standards of the building will not be at risk by complying with the previous requirements. When making the decision, a simple “yes” or “no” answer is not adequate. The building certifier must give reasons for the decision that will demonstrate how the proposal will meet the relevant regulations. Reasons for the decision should also be properly documented by the building certifier and attached to the development application. Master Builders recommend that the new provisions be applied to all alterations/additions as a matter of course.

#### **New Paths, Driveways etc.**

If a new path, driveway, fixture or landscaping which may bridge or damage an existing barrier installed prior to the new laws coming into force is proposed, then the existing termite barrier must be reinstated. Installation in accordance with the new requirements is recommended.

If contractors are carrying out the new work, they should recommend to the homeowner that they seek the advice of a licensed pest control applicator before the new work commences. If the homeowner chooses not to seek this advice, the contractor should inform the homeowner that reinstatement of the barrier is required and ongoing treatment may be difficult unless adequate provision is made to do so before the work is completed. The contractor should document all recommendations made to the homeowner and ask for responses from the homeowner to be in writing.

## Typical Termite Management Options Available To The Builder

(Note: Not all options are illustrated in this circular. Additional options are illustrated in AS3660.1 or should be discussed with the Pest Control Installer).

### Penetrations To Slab

Can be protected by:

- Collars, or
- Stainless steel mesh, or
- Graded stone, or
- Fully reticulated chemical system under slab

### Attachments To Buildings

Attachments to buildings such as downpipes and service pipes and structures such as steps, verandahs, access ramps, hot water systems or similar must be provided with a barrier system or be separated from the building by at least 25 mm to allow clear and

uninterrupted visual inspection of the inspection zone.

### Termite Resistant Materials

If the perimeter, underslab or penetrations to the slab are not protected, then all PBEs must be of termite resistant materials. This includes architraves, skirting, door jambs, window frames and reveals. It should also be noted that bracing, roof battens and all structural elements must also be of termite resistant materials. If no physical or chemical management system is installed and the builder relies totally on termite resistant PBES, termites can still easily gain access and cause significant damage to carpets, built in cupboards and vanity units, furniture, books, electrical wiring and even paper from plasterboard products. Any product containing cellulose is susceptible to attack.

#### Perimeter Barrier - Brick Veneer Slab On Ground

For monolithic slabs, only the perimeter and slab penetrations need a management system installed. The slab can be relied upon as a barrier in its own right. However, any construction joints/control joints must also be protected.

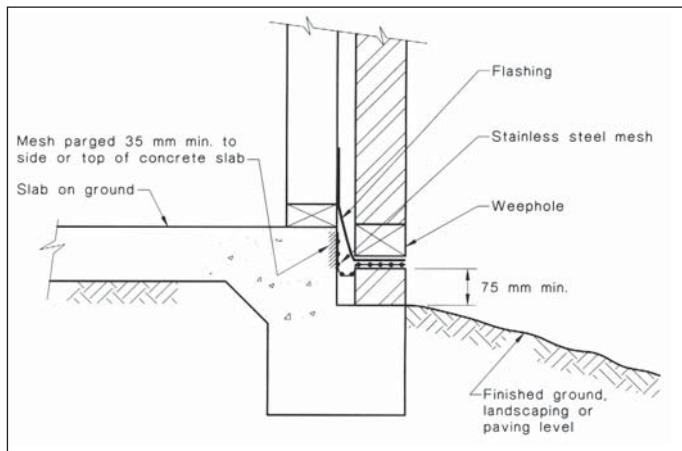

**STAINLESS STEEL MESH**

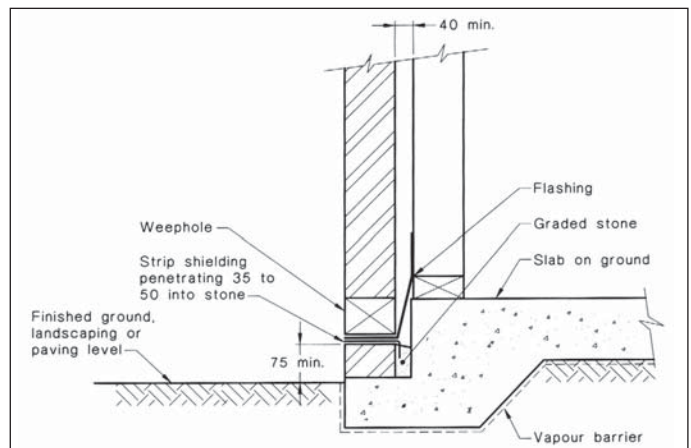

**GRADED STONE**

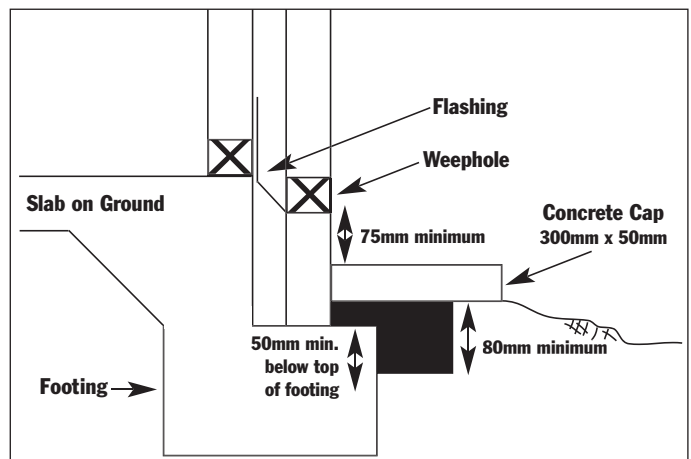

**CHEMICAL**

## Perimeter Barrier - Brick Veneer separate footing

For monolithic slabs where edge beams, stiffening beams, footing beams and retaining walls form part of the slab construction and they are:

- Placed as an integral component of the slab, or
- Tied together in accordance with AS2870, and the surface of the footing is cleaned prior to placing the slab, and
- The concrete is compacted to eliminate voids at the joint

Then termite treatment of the joint is not required.

**Where a non-monolithic slab is constructed, termites can still gain entry via the inside slab/ footing joint. Suitable management systems must be used to prevent termite entry via this point.**

*Note: The DPC is to be set a minimum of 20mm below top of slab as per AS2870.*

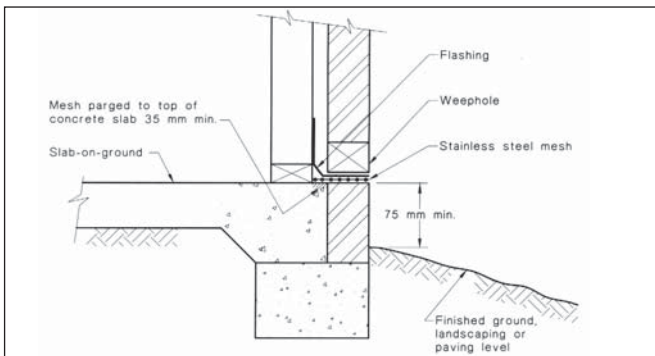

**STAINLESS STEEL MESH**

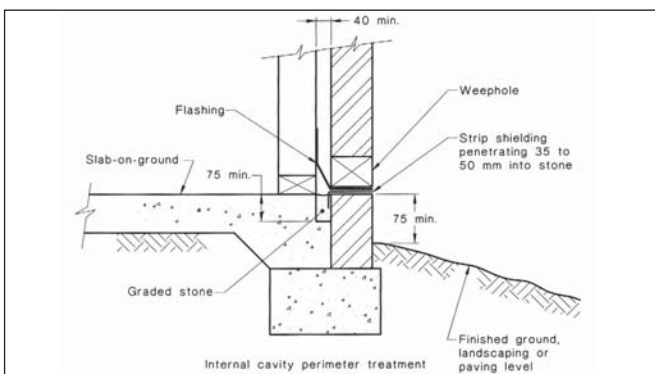

**GRADED STONE**

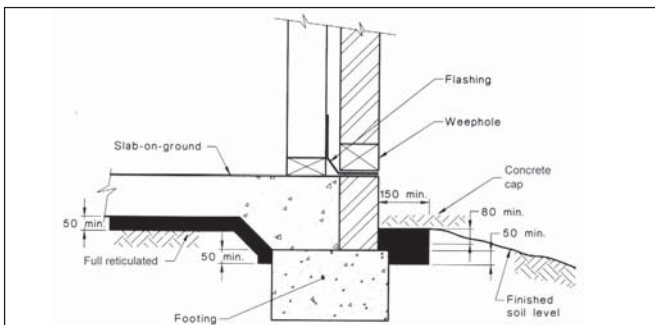

**CHEMICAL**

## Joints In Slabs

All construction joints and control joints must be protected. If a chemical system is installed, it must be via a reticulation system.

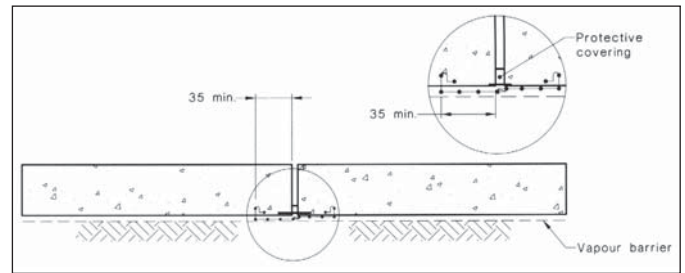

**STAINLESS STEEL**

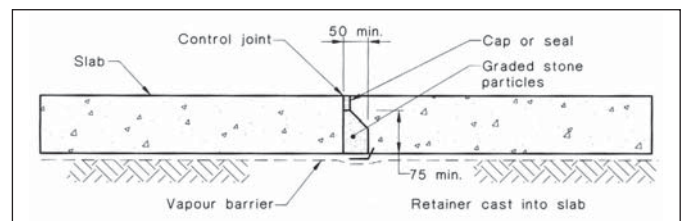

**GRADED STONE**

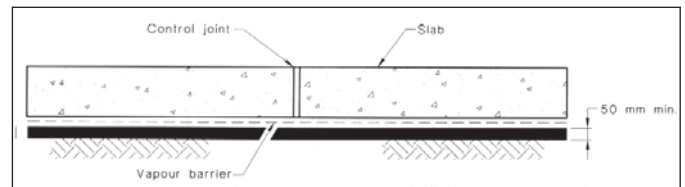

**RETICULATED CHEMICAL**

## Perimeter - Core Filled Blockwork

Specific advice should be obtained from a licenced pest control installer.

Chemicals used under a slab must be via a reticulated system.

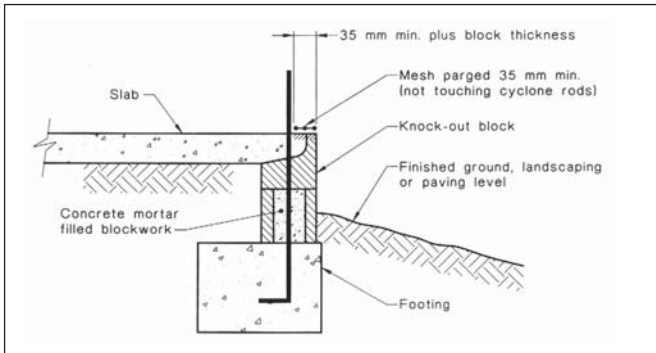

### STAINLESS STEEL

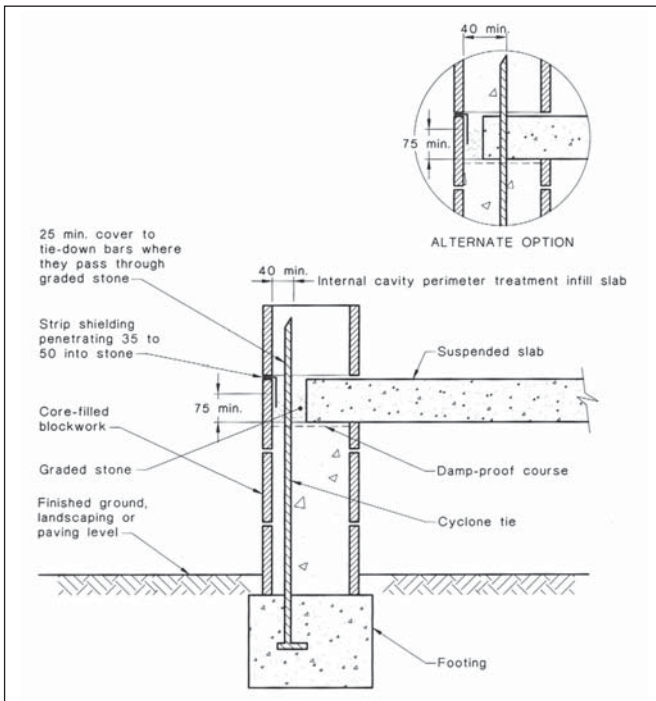

### GRADED STONE

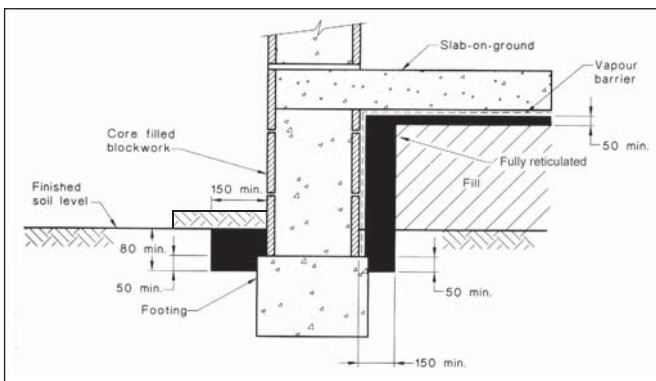

### CHEMICAL

## Change in Levels of Slabs

All construction joints must be managed to prevent termite entry.

Chemical treatment must be via a reticulated system.

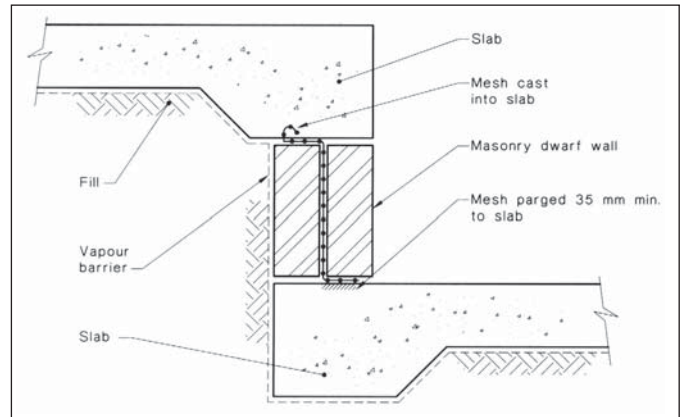

### STAINLESS STEEL

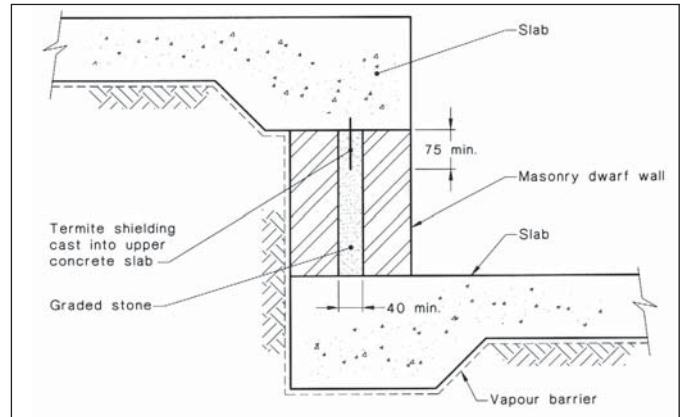

### GRADED STONE

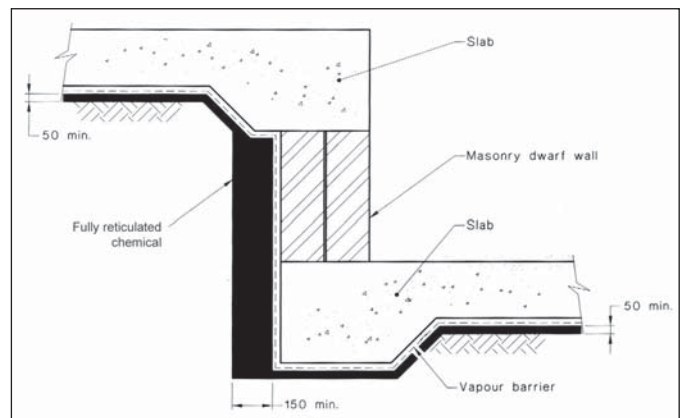

### RETICULATED CHEMICAL

## Perimeter Barrier - Slab Edge Exposure

This can only be used for monolithic slabs. A builder cannot simply hand over a site with 75 mm exposed slab edge having been formed by running a bobcat around the perimeter of the slab. The exposed edge must be 75mm above finished ground, landscaping or paving level. If the provision of landscaping, paving etc is not part of the builders contract, the builder should make allowance when finalising site levels to enable future work to occur so that 75 mm exposed slab edge will always be maintained. Penetrations to the slab must still be protected.

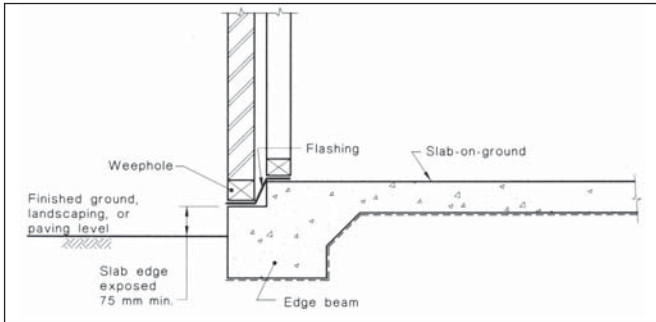

## Strip Shielding - Suspended Floors

A whole of house management system can be provided by the use of termite shielding in certain types of construction.

Alternatively, stainless steel mesh can be utilized. For suspended floors, a minimum clearance of 400mm must be maintained above finished ground level. On a sloping site the minimum clearance may be reduced to 150mm provided that the area generally slopes to 400mm clearance at not more than 2m from the area providing 150mm clearance.

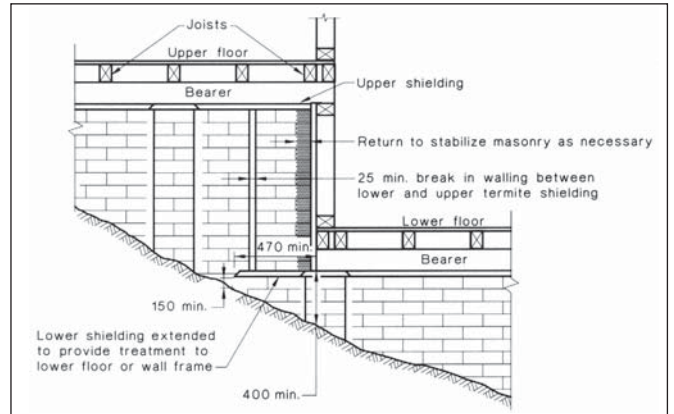

## Combination of Methods

A combination of methods may be used depending upon the method of construction and characteristics of the site.

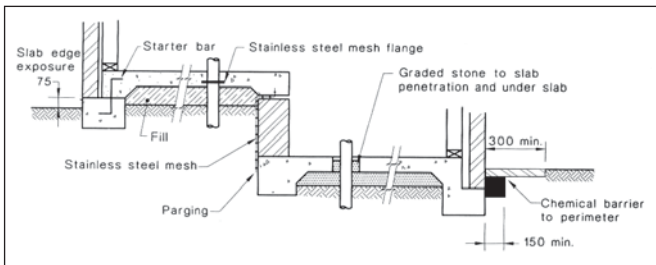

## Step by Step Guide for Builders

### Pre-contract Stage

- Issue Master Builders "Home Owner's Guide for Termite Management" to client.
- Discuss contents focusing on
  - Systems available - (physical / chemical)
  - Indicative costs of options
  - Ongoing homeowner's responsibilities regarding landscaping, maintenance, inspections and if chemicals are used, replenishment.
- Builder and owner agree which Termite Management System is to be adopted.
- Homeowner signs the "Declaration by Owner" and Builder retains a copy for job records.

### Contract Stage

- Detailed description of the system to be shown on plans by designer. A statement "Termite management in accordance with AS3660.1" is not considered to be an acceptable description.
- Discuss management system with selected licensed pest controller.
- Obtain "Certificate of Installation" from pest controller.
- Ensure two (2) durable notices are permanently fixed

in two (2) prominent locations eg. meter box and inside kitchen cupboard.

### **Practical Completion**

- Describe the Termite Management System installed to the owner.
- Highlight Owner's on going responsibilities (it is advisable to physically point out weepholes to the owner).

### **Post Contract**

- A reputable pest control company should maintain contact with the homeowner to ensure regular inspections are conducted at the required intervals.
- The builder should also maintain contact with the homeowner encouraging that regular inspections by a pestcontroller are maintained.

If the Builder can clearly demonstrate that termite management systems have been installed in accordance with AS3660.1-2000 and the Queensland BCA amendments, and the home owner

has been made aware of their obligations, then in the event of

a subsequent termite infestation it is unlikely the BSA will hold

the Builder liable. This document only provides guidance on some of the methods which can be used. Builders should rely on AS3660.1-2000 and the Queensland amendments to the BCA.